

Morgan Three Wheeler Starter. Part number 763309AXG

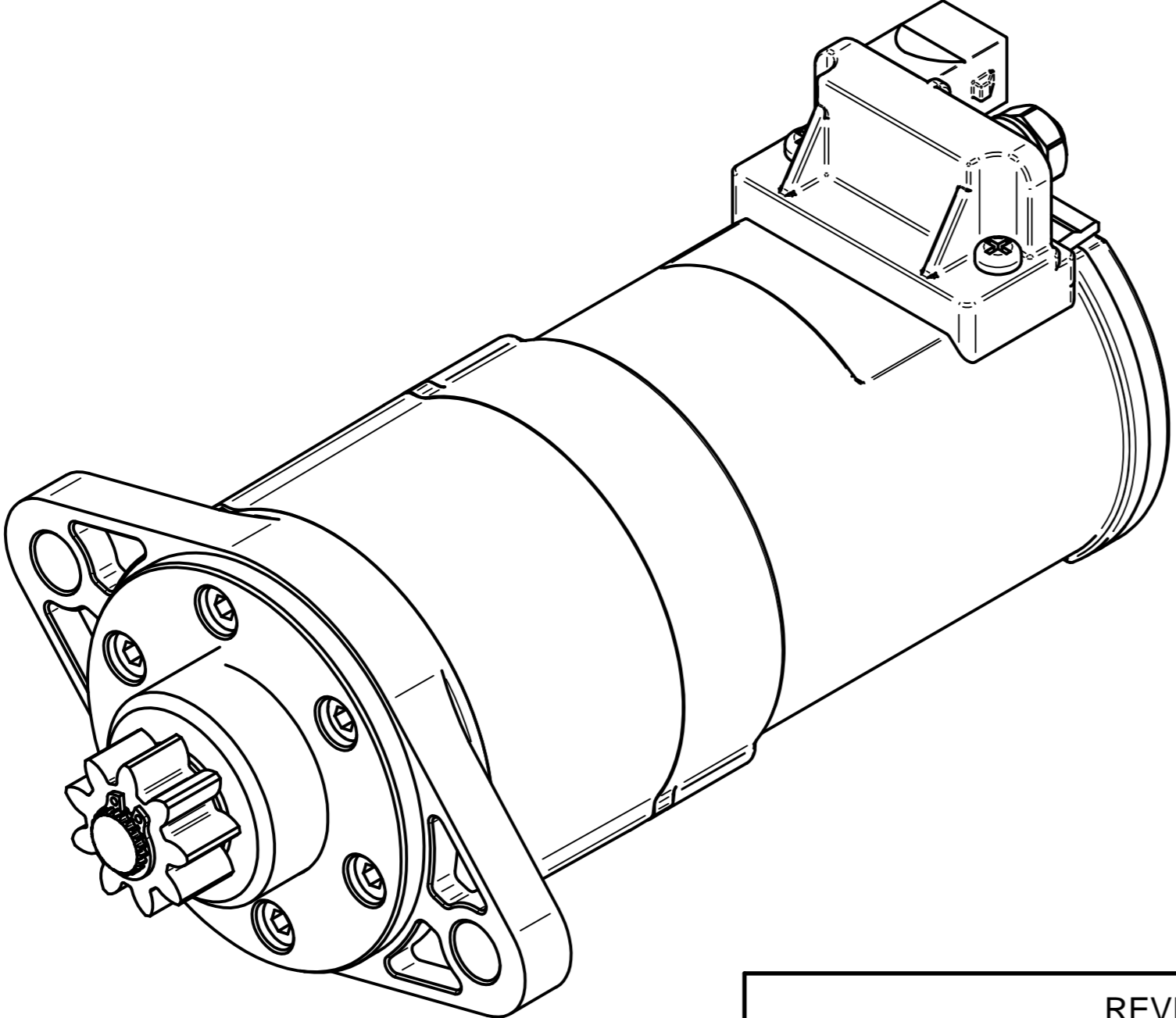
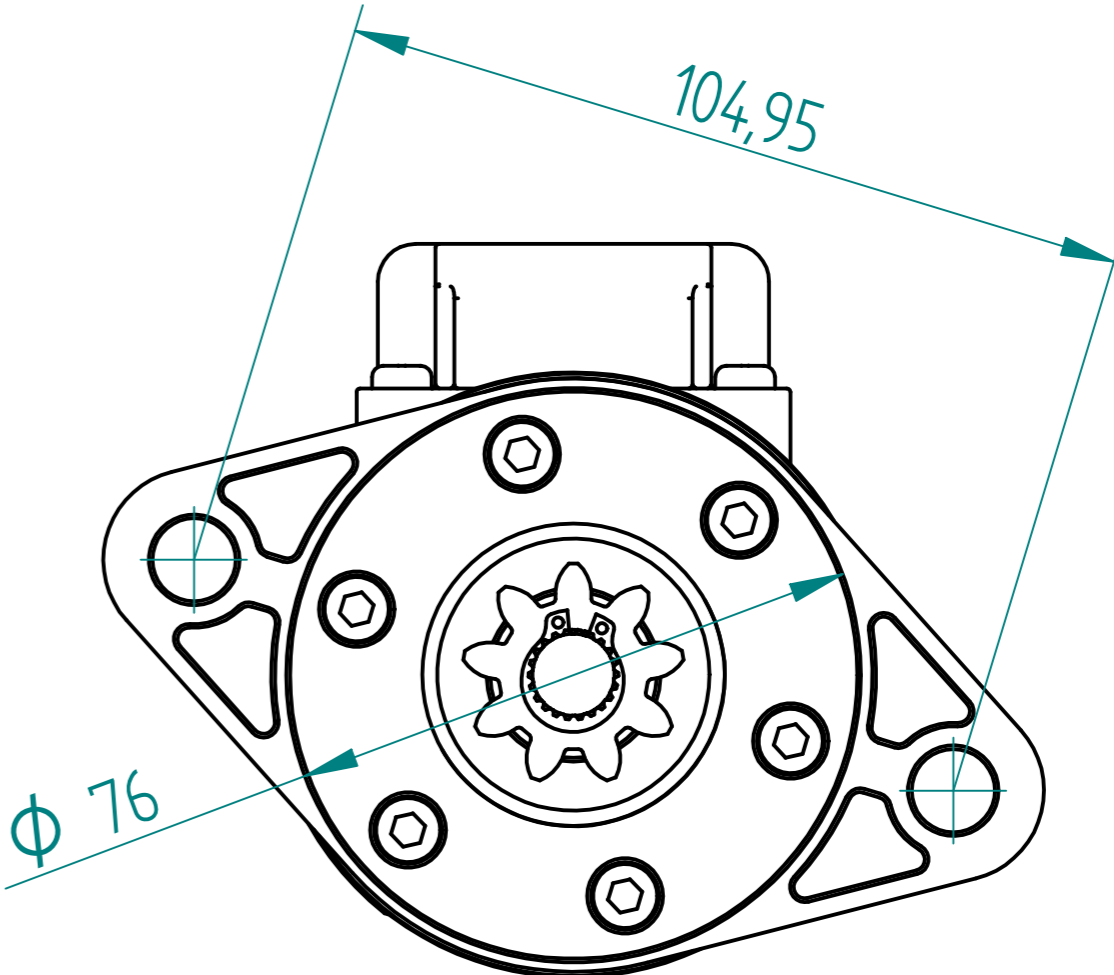
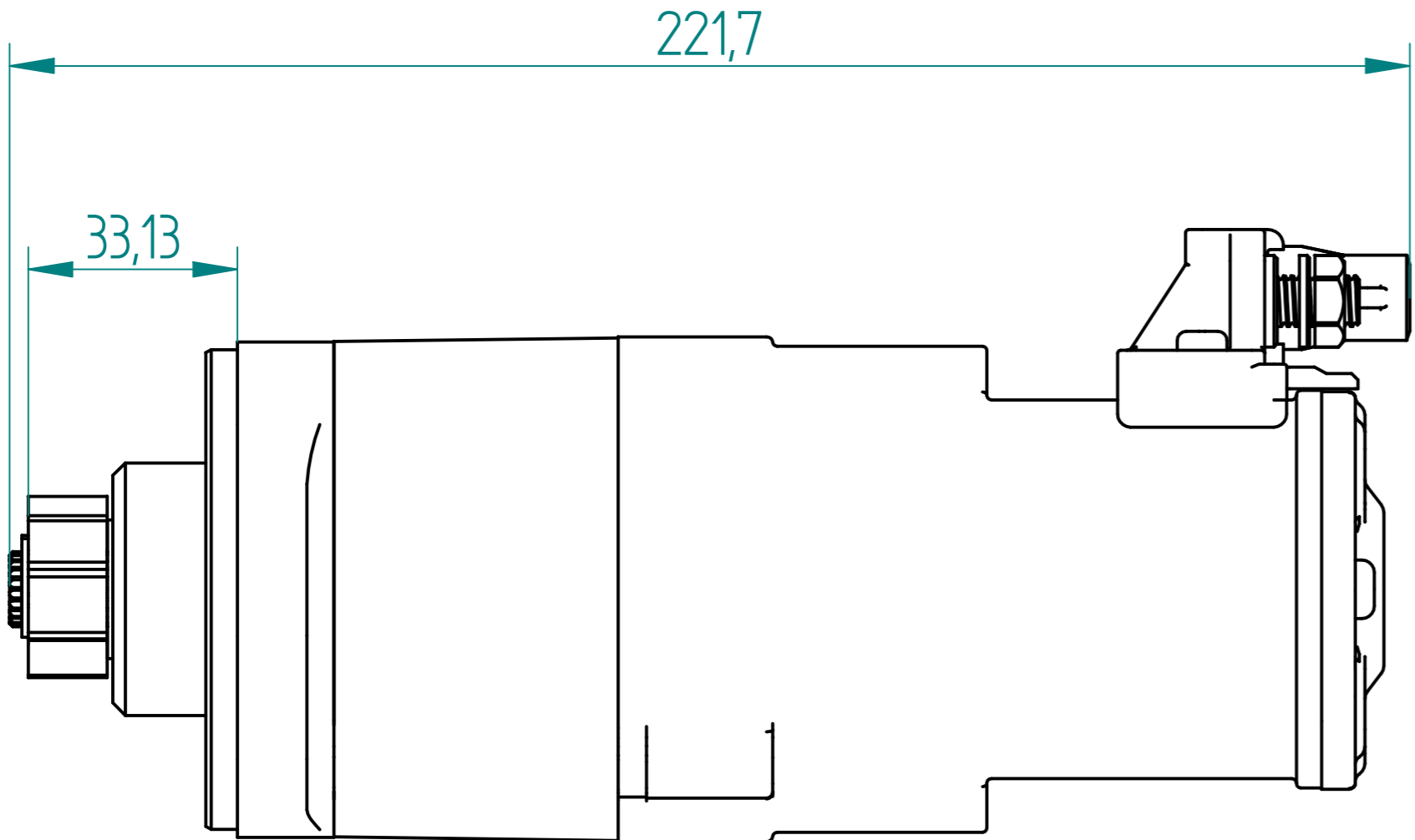

Material			Finish		
Drawn	Name	Date			
Checked	S.W.	27/10/10			
Appro					
Note.					
Unless otherwise stated all dimensions in mm.			Project: Morgan Three Wheeler Starter.		
			Item: 763309AXG		
			Maximum Torque:		
Status			Scale 1:1	Sheet 1 of 1	Mass: 2.7kg
© Copyright Brise Ltd. Unit Q3 Northfleet Industrial Estate DA11 9SN All Rights Reserved					

REVISION HISTORY			
REV.	DESCRIPTION	DATE	APPRO